

Solenoid modular valves

direct, modular, spool type

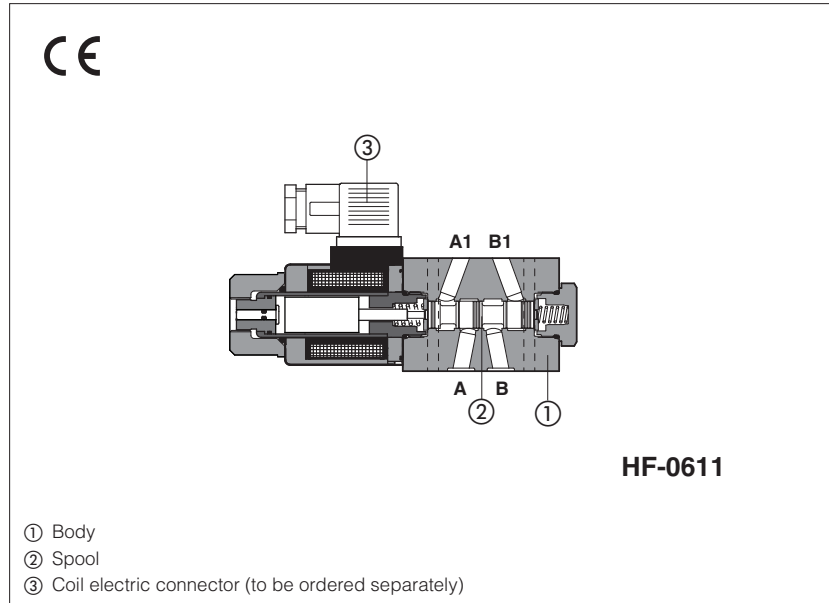

HF are spool type, direct operated solenoid valves in modular execution, normally used for shut-off or to by-pass the hydraulic user lines.

The modular execution permits to make compact functional circuits, by the stack mounting with other modular valves and solenoid valves size 06.

Mounting Surface: **ISO 4401 size 06**

Max flow: **60 l/min**

Max pressure: **350 bar**

1 MODEL CODE

HF-0	611	/ A	-	E	X	24DC	**	/*
Modular directional valve, size 06							Series number	Seals material, see section 4: - = NBR PE = FKM BT = HNBR
Valve configuration and spool: 611, 613, 614, 673 see section 2						Voltage code , see section 7		
Options: A = solenoid mounted at side of port B (not for 673) B = orientation of coil rotated of 180° WP = prolonged manual override protected by a rubber cap						X = without connector See section 6 for available connectors, to be ordered separately Coils with special connectors XJ = AMP Junior Timer connector XK = Deutsch connector XS = Lead Wire connection		
						E = solenoid OE for AC and DC supply		

2 CONFIGURATION

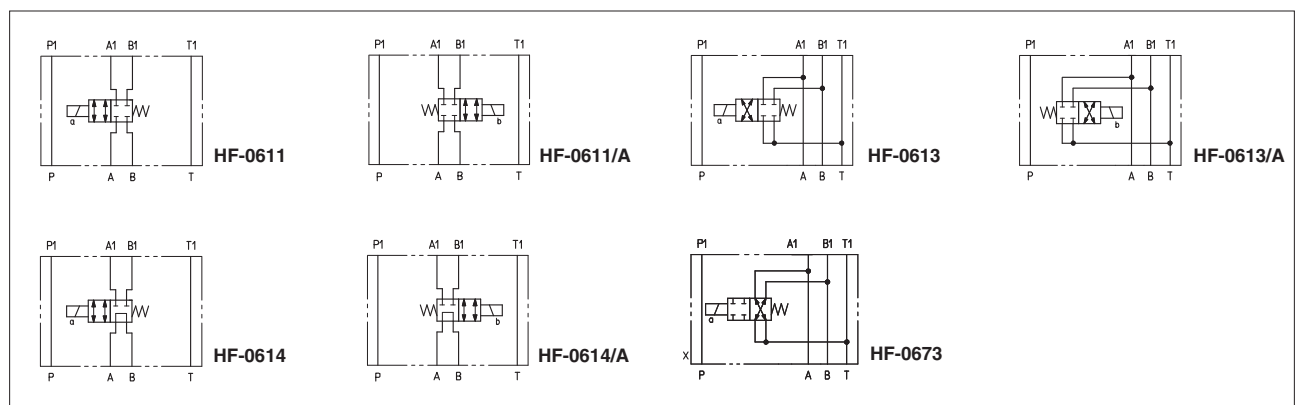

3 MAIN CHARACTERISTICS

Assembly position / location	Any position
Subplate surface finishing	Roughness index Ra 0,4 - flatness ratio 0,01/100 (ISO 1101)
MTTFd values according to EN ISO 13849	150 years, for further details see technical table P007
Compliance	CE to Low Voltage Directive 2014/35/EU and Machine Directive 2006/42/EC. RoHS Directive 2011/65/EU as last update by 2015/863/EU REACH Regulation (EC) n°1907/2006
Ambient temperature	Standard -30°C ÷ +70°C /PE option -20°C ÷ +70°C /BT option -40°C ÷ +70°C
Flow direction	As shown in the symbols of table 2
Operating pressure	Ports P,A,B: 350 bar Port T: 210 bar (DC solenoid); 160 bar (AC solenoid)
Maximum flow	60 l/min

3.1 Coils characteristics

Insulation class	H (180°C) for DC coils; F (155°C) for AC coils Due to the occurring surface temperatures of the solenoid coils, the European standards EN ISO 13732-1 and EN ISO 4413 must be taken into account
Protection degree to DIN EN 60529	IP 65 (with connectors correctly assembled)
Relative duty factor	100%
Supply voltage and frequency	See electric features 7
Supply voltage tolerance	± 10%
Certification	cURus North American standard

4 SEALS AND HYDRAULIC FLUID - for other fluids not included in below table, consult our technical office

Seals, recommended fluid temperature	NBR seals (standard) = -20°C ÷ +80°C, with HFC hydraulic fluids = -20°C ÷ +50°C FKM seals (/PE option) = -20°C ÷ +80°C HNBR seals (/BT option) = -40°C ÷ +60°C, with HFC hydraulic fluids = -40°C ÷ +50°C		
Recommended viscosity	15÷100 mm ² /s - max allowed range 2,8 ÷ 500 mm ² /s		
Max fluid contamination level	ISO4406 class 20/18/15 NAS1638 class 9, see also filter section at www.atos.com or KTF catalog		
Hydraulic fluid	Suitable seals type	Classification	Ref. Standard
Mineral oils	NBR, FKM, HNBR	HL, HLP, HLPD, HVLP, HVLPD	DIN 51524
Flame resistant without water	FKM	HFDU, HFDR	ISO 12922
Flame resistant with water	NBR, HNBR	HFC	

5 OPTIONS

A = Solenoid mounted at side of port B. In standard versions, solenoid is mounted at side of port A.

B = Orientation of coil and proximity connectors rotated of 180°



WP = Prolonged manual override protected by a rubber cap

6 ELECTRIC CONNECTORS ACCORDING TO DIN 43650 (to be ordered separately)

666, 667 (for AC or DC supply)	669 (for AC supply)	CONNECTOR WIRING		
		666, 667		669
		1 = Positive. ⊕ 2 = Negative. ⊖ ⊕ = Coil ground		1,2 = Supply voltage V _{AC} 3 = Coil ground
SUPPLY VOLTAGES				
666	667	669		
All voltages	24 AC or DC 110 AC or DC 220 AC or DC	110/50 AC 110/60 AC 230/50 AC 230/60 AC		

Note: for electronic connectors type **E-SD**, see tab. K500

7 ELECTRIC FEATURES

External supply nominal voltage ± 10%	Voltage code	Type of connector	Power consumption (2)	Code of spare coil	
12 DC	12 DC	666 or 667	30 W	COE-12DC	
14 DC	14 DC			COE-14DC	
24 DC	24 DC			COE-24DC	
28 DC	28 DC			COE-28DC	
48 DC	48 DC			COE-48DC	
110 DC	110 DC			COE-110DC	
125 DC	125 DC			COE-125DC	
220 DC	220 DC			COE-220DC	
110/50 AC	110/50/60 AC			58 VA (3)	COE-110/50/60AC (1)
230/50 AC	230/50/60 AC				COE-230/50/60AC (1)
115/60 AC	115/60 AC	80 VA (3)	COE-115/60AC		
230/60 AC	230/60 AC		COE-230/60AC		
110/50 AC - 120/60 AC	110 RC	669	30 W	COE-110RC	
230/50 AC - 230/60 AC	230 RC			COE-230RC	

- (1) Coil can be supplied also with 60 Hz of voltage frequency: in this case the performances are reduced by 10 ÷ 15% and the power consumption is 52 VA.
 (2) Average values based on tests performed at nominal hydraulic condition and ambient/coil temperature of 20°C.
 (3) When solenoid is energized, the inrush current is approx 3 times the holding current.

8 Q/ΔP DIAGRAMS based on mineral oil ISO VG 46 at 50°C

Flow direction Valve type	A→A1	B→B1	A→B	A1→T	B1→T
	HF-0611	2	3		
HF-0613	6	6		5	4
HF-0614	2	3	1		
HF-0673	6	6		4	5

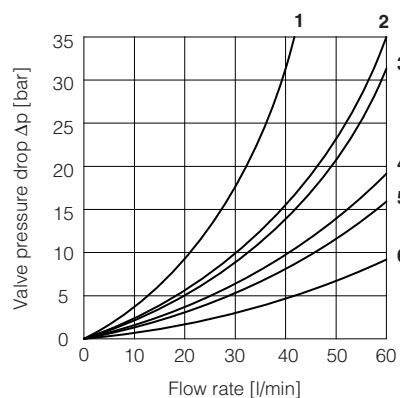

9 OPERATING LIMITS based on mineral oil ISO VG 46 at 50°C

The diagrams have been obtained with warm solenoids and power supply at lowest value ($V_{nom} - 10\%$)

Valve type	Curve
HF-0611	A
HF-0614, HF-0673	B

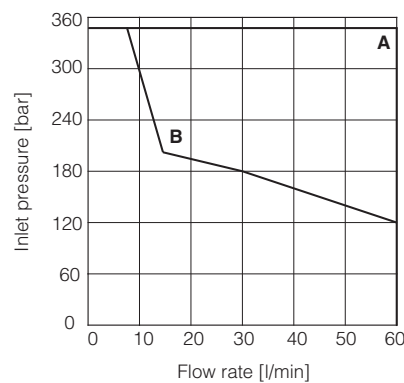

10 DIMENSIONS [mm]

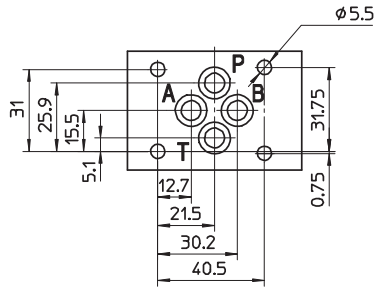

ISO 4401: 2005
Mounting surface: 4401-03-02-0-05
 Seals: 4 OR 108
 Ports P, A, B, T: $\phi = 7.5$ mm (max).

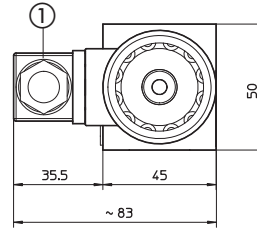
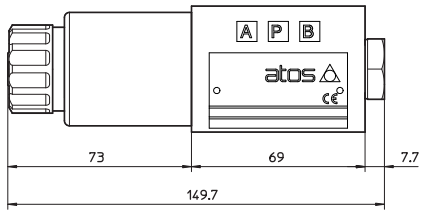

HF-0611
HF-0613
HF-0614
HF-0673

① = Power supply connector code 666, 667 or 669, to be ordered separately